

# Vibrosetaccio TR 40

*Vibrating Sieve*  
*TR 40*



Indispensabili nel **processo di recupero dei metalli preziosi** per il trattamento delle ceneri da avviare alla fusione, all'assaggio o alla macinatura e per la loro deferrizzazione tramite supporti magnetici manuali o automatici.

*Machineries indispensable in the **precious metals recovery process** for the treatment of the dusts (ashes) to forward to the melting, the assaying, the crushing and for their deferrization by mean of manual or automatic magnetic devices.*

# Vibrosetaccio TR 40

## *Vibrating Sieve TR 40*

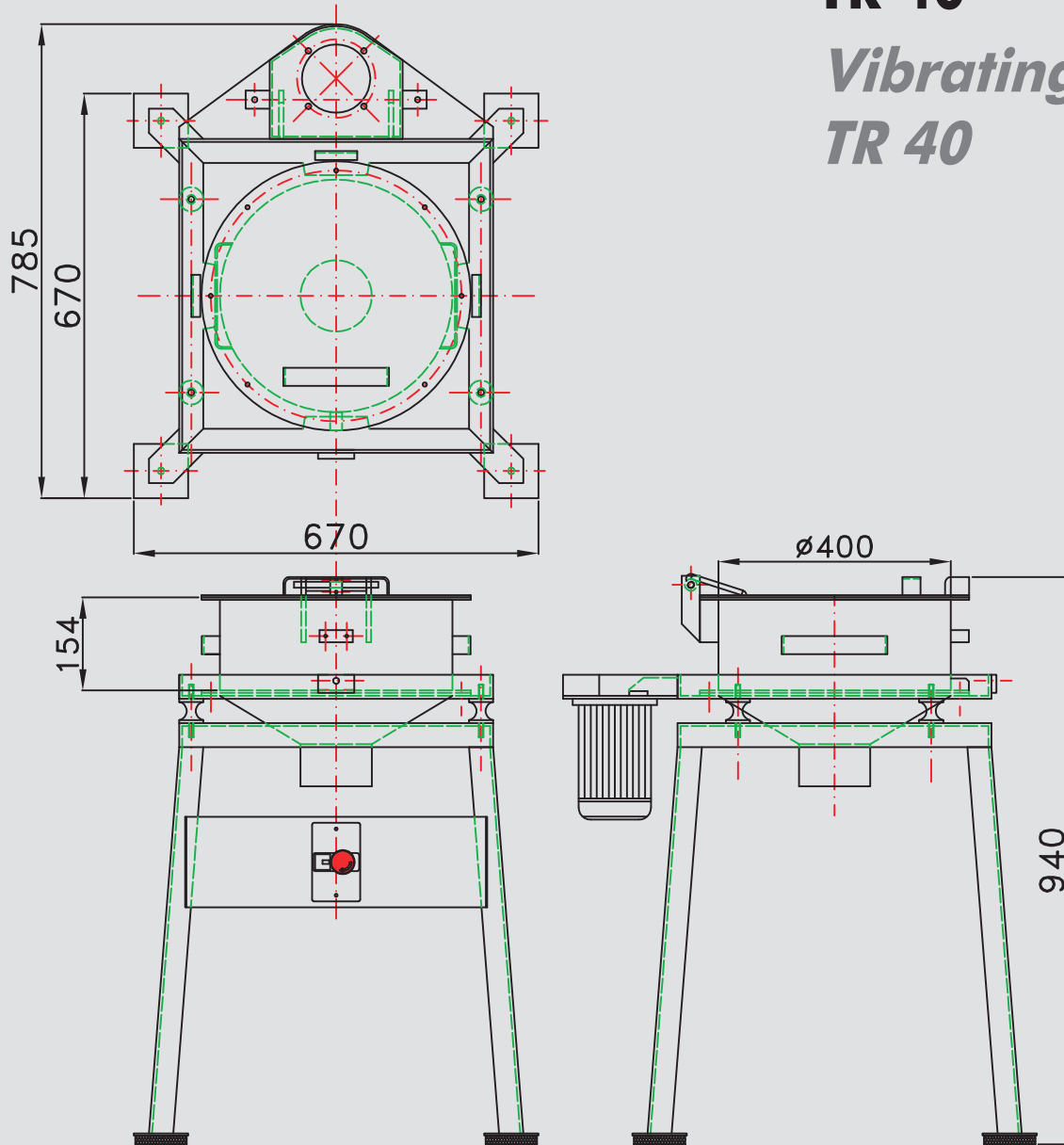

### **Caratteristiche principali**

Peso complessivo: kg. 50  
Potenza elettrica: KW 0,55  
Standard applicati: CE  
Diametro tramoggia: mm 400  
Rete: in AISI 304  
N° di mesh: in base alle esigenze produttive

### **Main features TR 40**

Total weight: kgs. 50  
Electric power: KW 0,55  
Standard: CE  
Hopper diameter: mm 400  
Net: in stainless steel  
Mesh N°: on the basis of the production needs

